

GROSSMONT
COLLEGE



GROSSMONT COLLEGE
Facilities Committee
March 6, 9:30am-11:00am
Location: Zoom

[Join Zoom Meeting](#)

AGENDA

Purpose The Facilities Committee identifies prioritizes and advocates for the facilities needs and services. It makes recommendations to the College Council for the strategic direction and implementation of facilities priorities. These recommendations address facilities policies and procedures, prioritization of facilities requests from annual unit plans*, facility requirements for existing programs, and projected facility needs of the college for the future. The committee will ensure that its recommendations are consistent with the objectives and recommendations established in the Facilities Plan, Strategic Plan, Educational Master Plan, and other supporting plans and reports (five-year capital outlay plan, use of space, scheduled maintenance, state and federal reports, etc.).

CO-CHAIRS	ASSOCIATED STUDENTS OF GROSSMONT COLLEGE	ADVISORY
<input checked="" type="checkbox"/> Loren Holmquist	<input type="checkbox"/> Renzo Tayag	<input checked="" type="checkbox"/> Agustin Albarran
<input checked="" type="checkbox"/> Jennifer Bennett	<input type="checkbox"/> Elliana Capurro	<input type="checkbox"/> Marsha Gable
		<input type="checkbox"/> Jason Allen
		<input checked="" type="checkbox"/> Reyna Torriente

ACADEMIC SENATE	CLASSIFIED SENATE	ADMINISTRATORS' ASSOCIATION
<input checked="" type="checkbox"/> Jennifer Bennett	<input type="checkbox"/> Rochelle Weiser	<input checked="" type="checkbox"/> Maura Mehrian
<input checked="" type="checkbox"/> Michael Bacon	<input type="checkbox"/> Chad Deitchman	<input checked="" type="checkbox"/> Vanessa Fountain

EX-OFFICIO	RECORDER	Campus Art Committee
<input checked="" type="checkbox"/> Patrice Braswell-Burris	<input checked="" type="checkbox"/> Colleen Parsons	<input checked="" type="checkbox"/> Jennifer Bennett
<input type="checkbox"/>		

ROUTINE BUSINESS

Welcome and Introductions – Jennifer Bennett	
Establish Quorum– Jennifer Bennett	Quorum not met
Additions/Deletions to Agenda – Jennifer Bennett	None
Approve Meeting Notes & Follow-up – Jennifer Bennett	Quorum not met
5-Minute Public Comment – Jennifer Bennett	Thanks to grounds for a beautiful campus

NEW BUSINESS

Final FPR Prioritization – Loren Holmquist	<i>Quorum not met just questions asked and answered. Discussions on reflection room. Maura to move to the next month's meeting due to lack of quorum & discussion. Jennifer Seconded.</i>
Sculpture – Jennifer Bennett	Michael Bacon moves that Facilities committee is to look at the ideas for sculptures and supports the idea pending sketches. Dr. Fountain seconds motion See PowerPoint

COMMITTEE REPORTS

Constituency Updates ASGC, Academic Senate, Classified Senate, Administrators Association	AA-Updates on the PC committee Classified-None Academic- Facilities Staffing questions
Space Utilization – Loren Holmquist	College Council recommended
Construction Timeline and Campus Impacts – Loren Holmquist	See Power Point Questions on name plates & storm damages updates

INFORMATION AND DISCUSSION

FOR CONSENSUS

Previous Meeting Minutes	Quorum not met

FOLLOW-UP

Who	Item	Timeline

1. WORK AHEAD

-

NEXT MEETING: April 3, 2024

WELCOME TO THE FACILITIES COMMITTEE

The best way to contact FMO is by email

Grossmont.FMO@gcccd.edu

For maintenance, grounds, custodial and operation needs

Colleen Parsons, Ryan Althaus, Bill Roessner, Pepe Levy, Joel Lopez

Grossmont.restrooms@gcccd.edu

For restrooms that need attention

FMO phone is not monitored 24/7

619-644-7594

FACILITIES COMMITTEE AGENDA

1. Welcome/Introductions – Jennifer Bennett
2. Agenda – Additions/Deletions – Jennifer Bennett
3. Approve Meeting Minutes – Jennifer Bennett
4. 5-Minute Public Comment – Jennifer Bennett
5. Constituency Updates – Jennifer Bennett
 1. Admin Association
 2. Classified Senate
 3. Academic Senate
 4. ASGC
6. Space Utilization Update – Loren Holmquist
7. **Sculpture Campus Art – Jennifer Bennett**
8. AUP / FPR Prioritization – Loren Holmquist
9. Construction Timeline and Impacts – Loren Holmquist
10. Constituency Group Recap - Jennifer Bennett

DATE 3/6/24

Possible Locations for Artwork on Grossmont College Campus

Work to be created by SP24 Sculpture II Students

Possible mediums: Formed wire mesh , cast hydro stone



1.
Native Plant Garden





2.

The tree in the
foreground near the
quad
(east of ceramics bldg.)

Or

3 Trees in the
background of the
picture

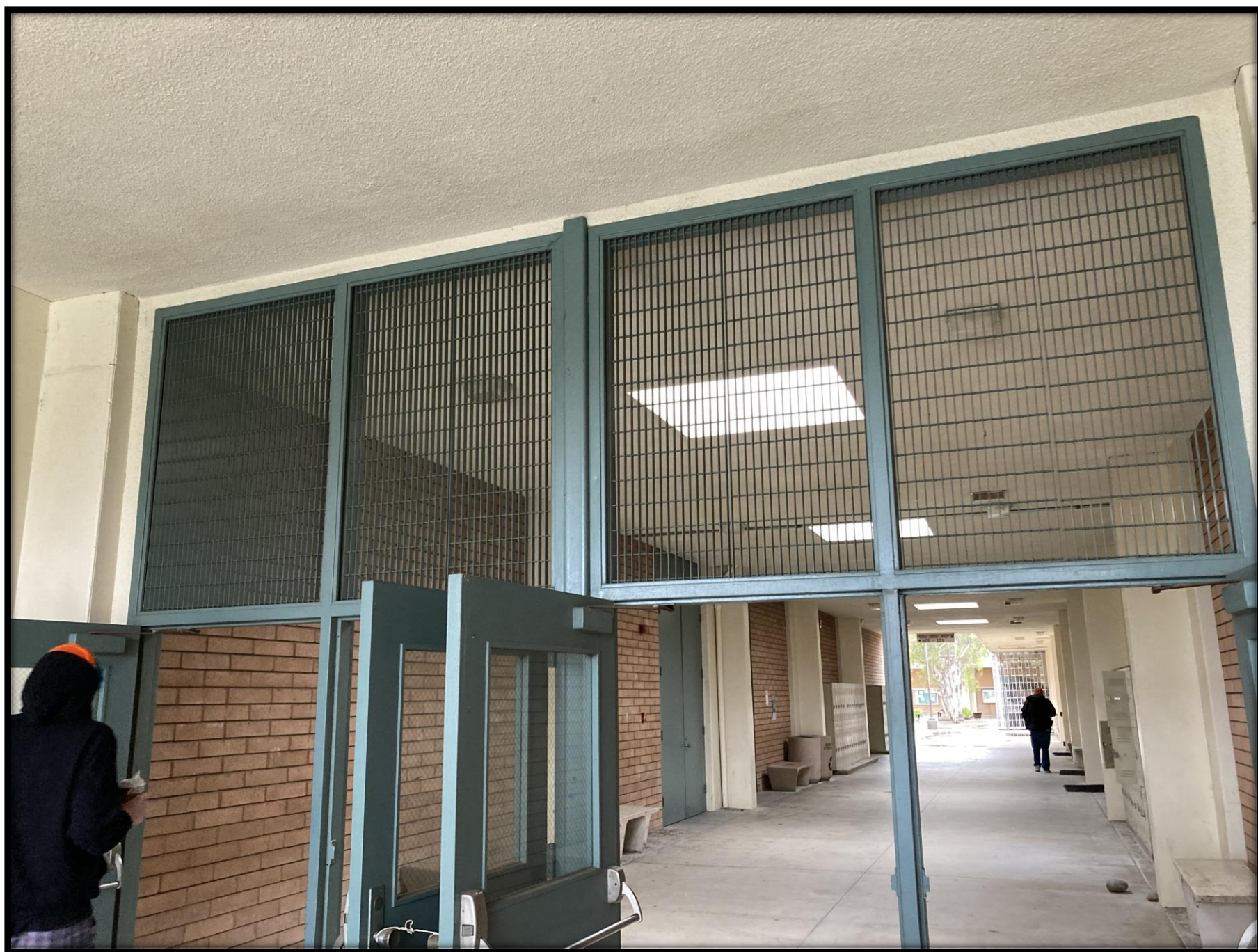

3.
Grating above doors that
access the Art courtyard in
the middle of bldgs. 24, 25,
26, 27



4.
Under the bridge
btw buildings 31
and 34



5.
Green Hill Space
(south of building
51)



6.
Metal Grid
with Vines
on the south
side of
Building 71





Thank You!

FACILITIES COMMITTEE AGENDA

1. Welcome/Introductions – Jennifer Bennett
2. Agenda – Additions/Deletions – Jennifer Bennett
3. Approve Meeting Minutes – Jennifer Bennett
4. 5-Minute Public Comment – Jennifer Bennett
5. Constituency Updates – Jennifer Bennett
 1. Admin Association
 2. Classified Senate
 3. Academic Senate
 4. ASGC
6. Space Utilization Update – Loren Holmquist
7. Sculpture Campus Art – Jennifer Bennett
8. **AUP / FPR Prioritization – Loren Holmquist**
9. Construction Timeline and Impacts – Loren Holmquist
10. Constituency Group Recap - Jennifer Bennett

DATE 3/6/24

FPR 24-01 Mental Health Space

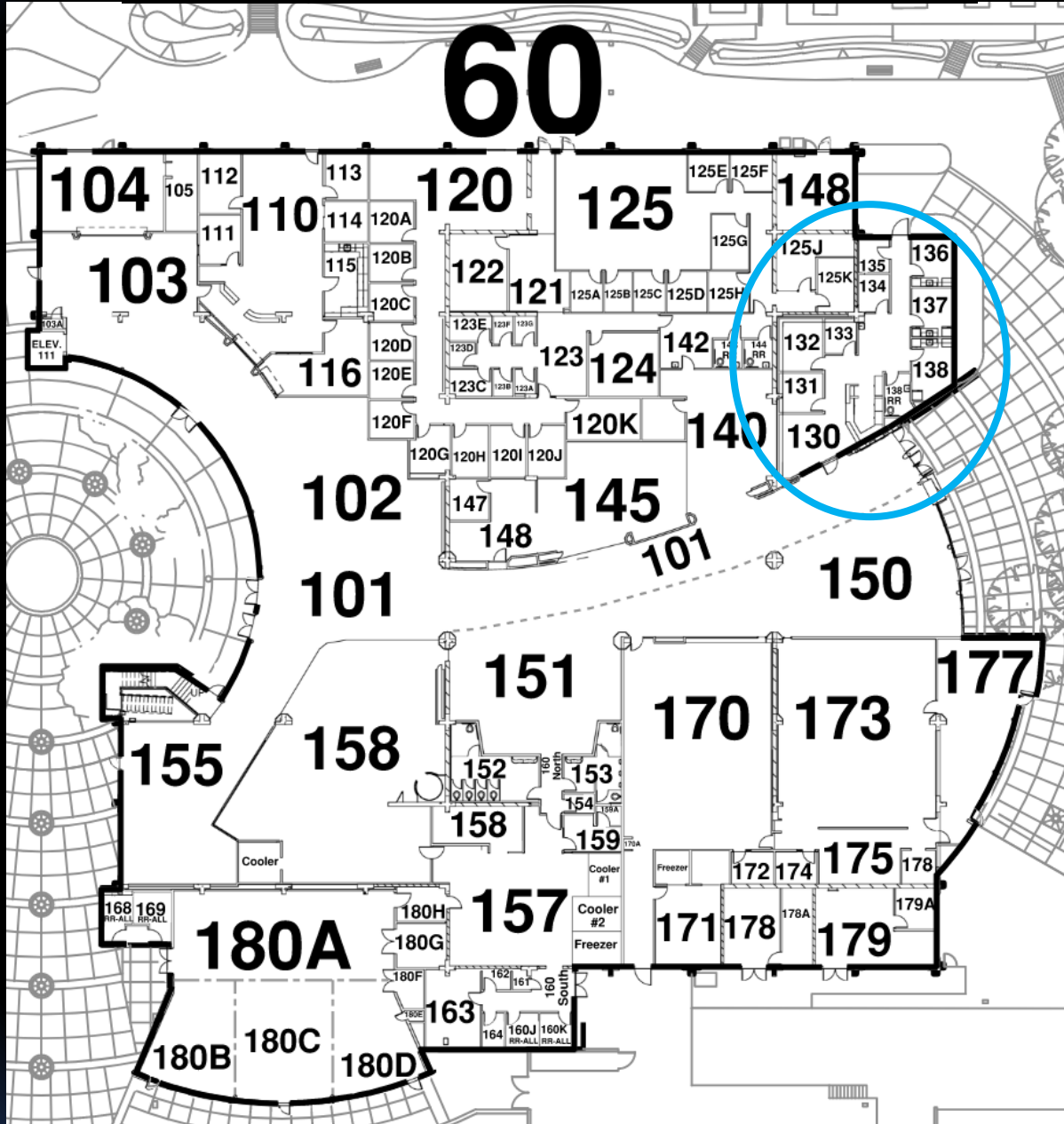

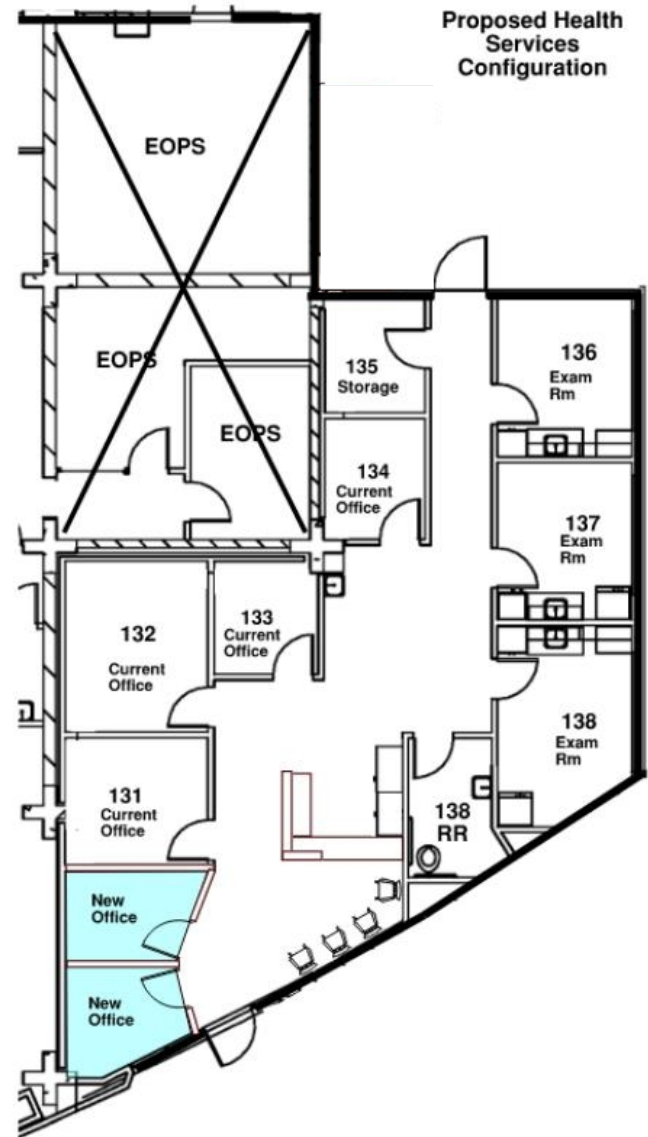
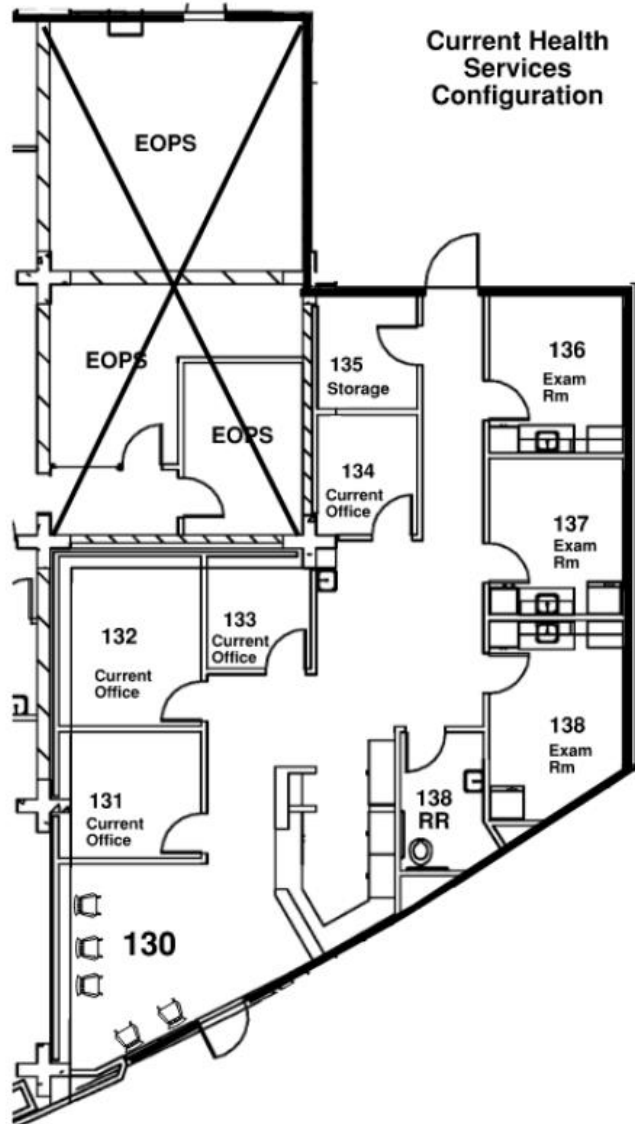

Before



After

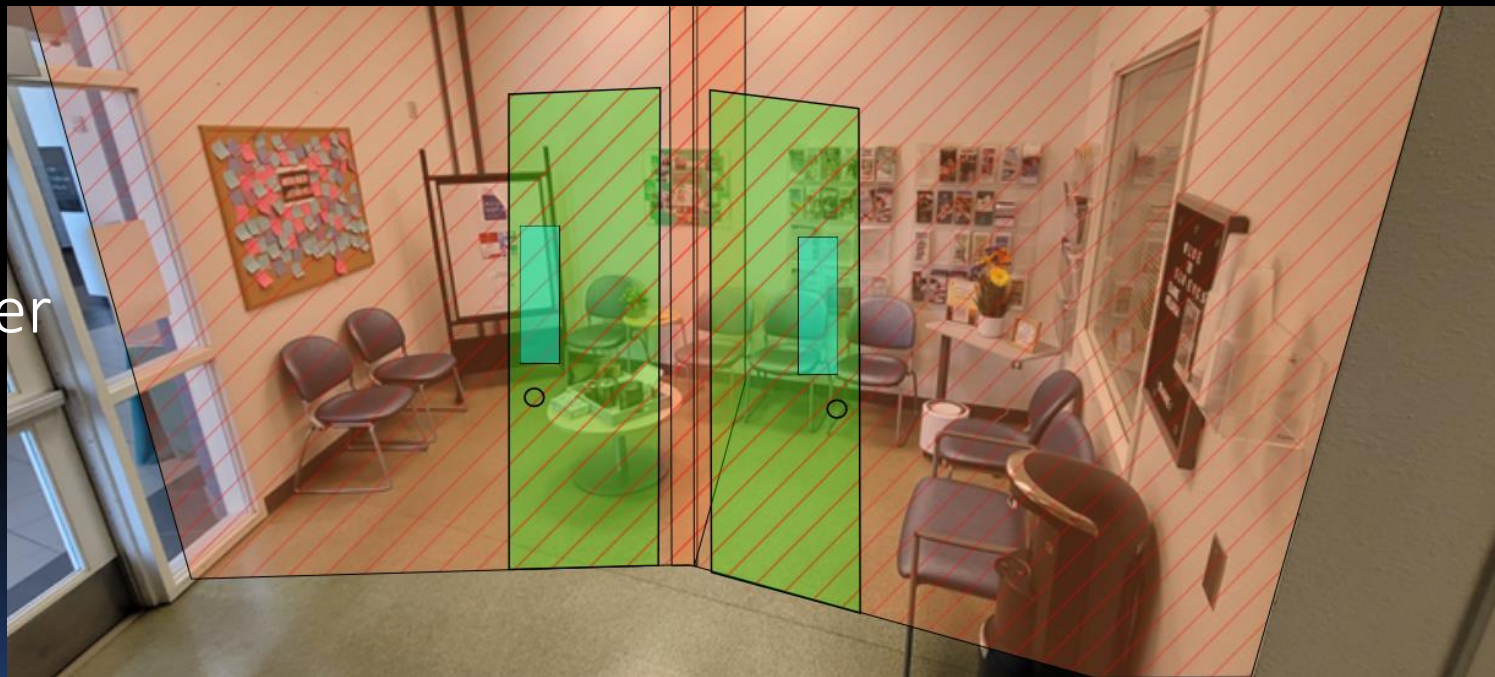

FPR 24-03 Welcome Desk

10

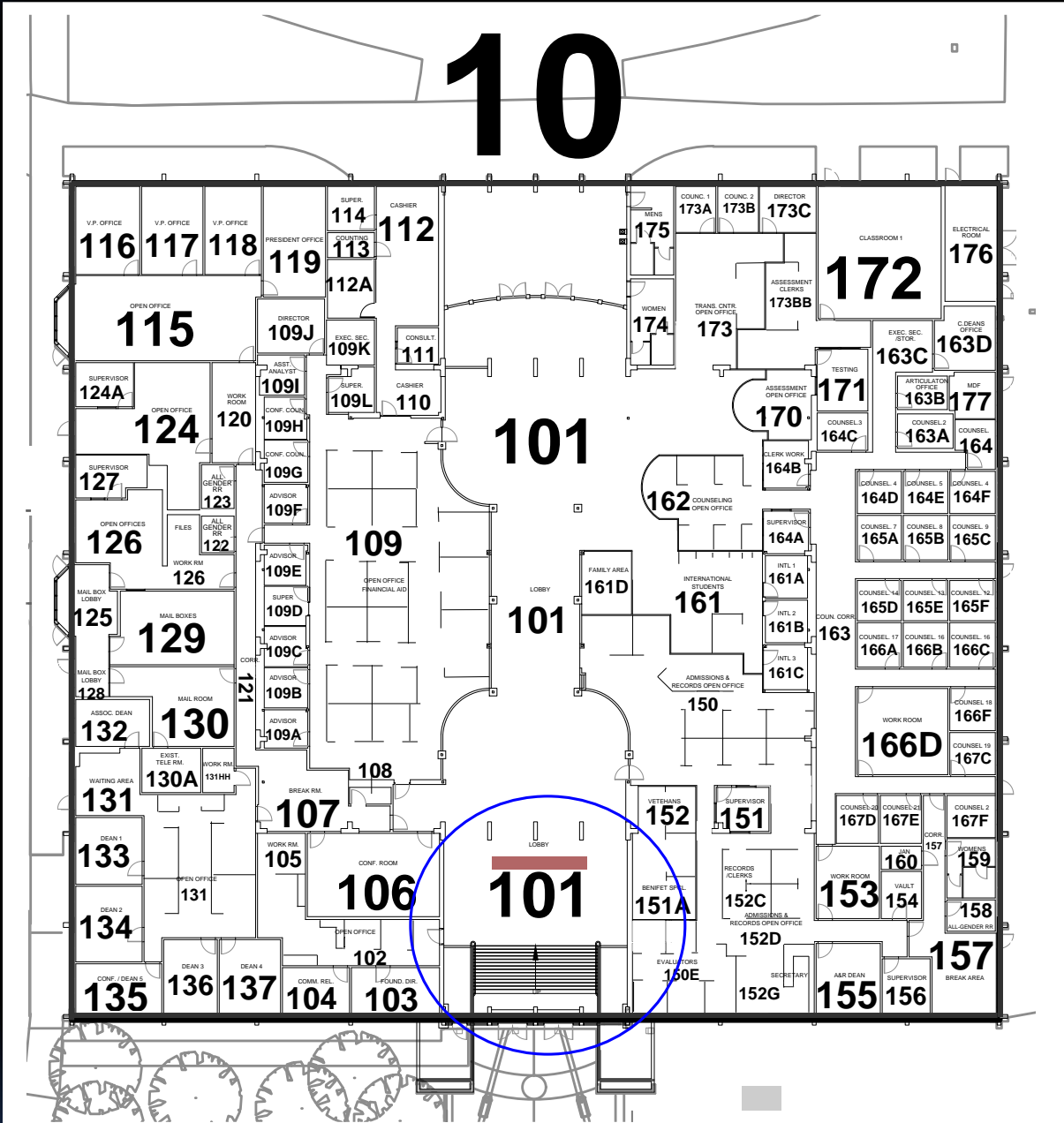

FPR 24-02 Welcome Desk



WELCOME
DESK
ASK US
Need to be checked
in somewhere?
Need info on
programs/
services?

FREE COLLEGE?
McCollege at Grossmont
McCollege at Foothill

FAPSA

SOCIAL
DISTANCING
PLEASE
STAND HERE

FPR 24-02 Welcome Desk

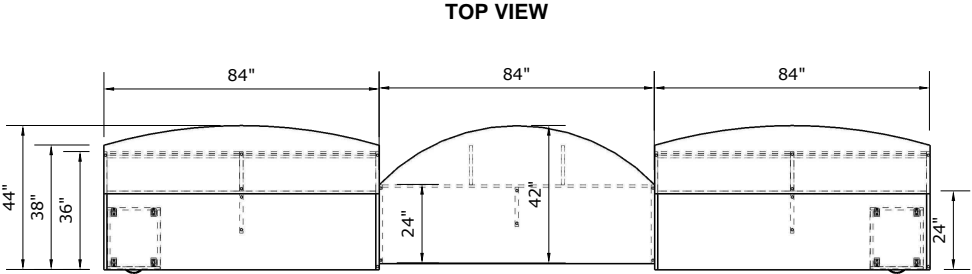
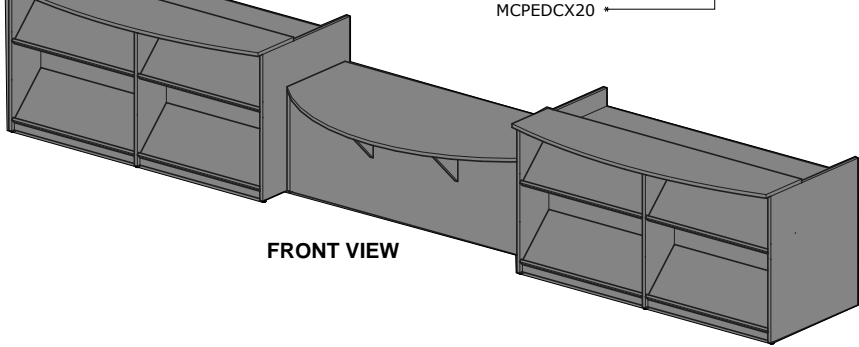
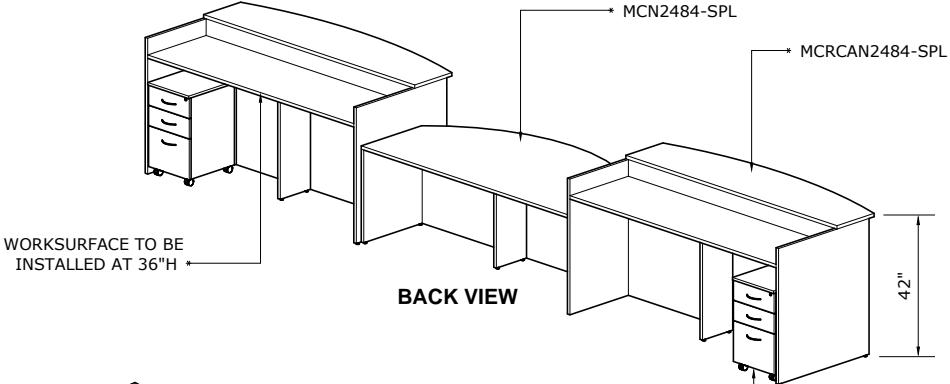

FPR 24-02 Welcome Desk



FPR 24-03 Reflection Room

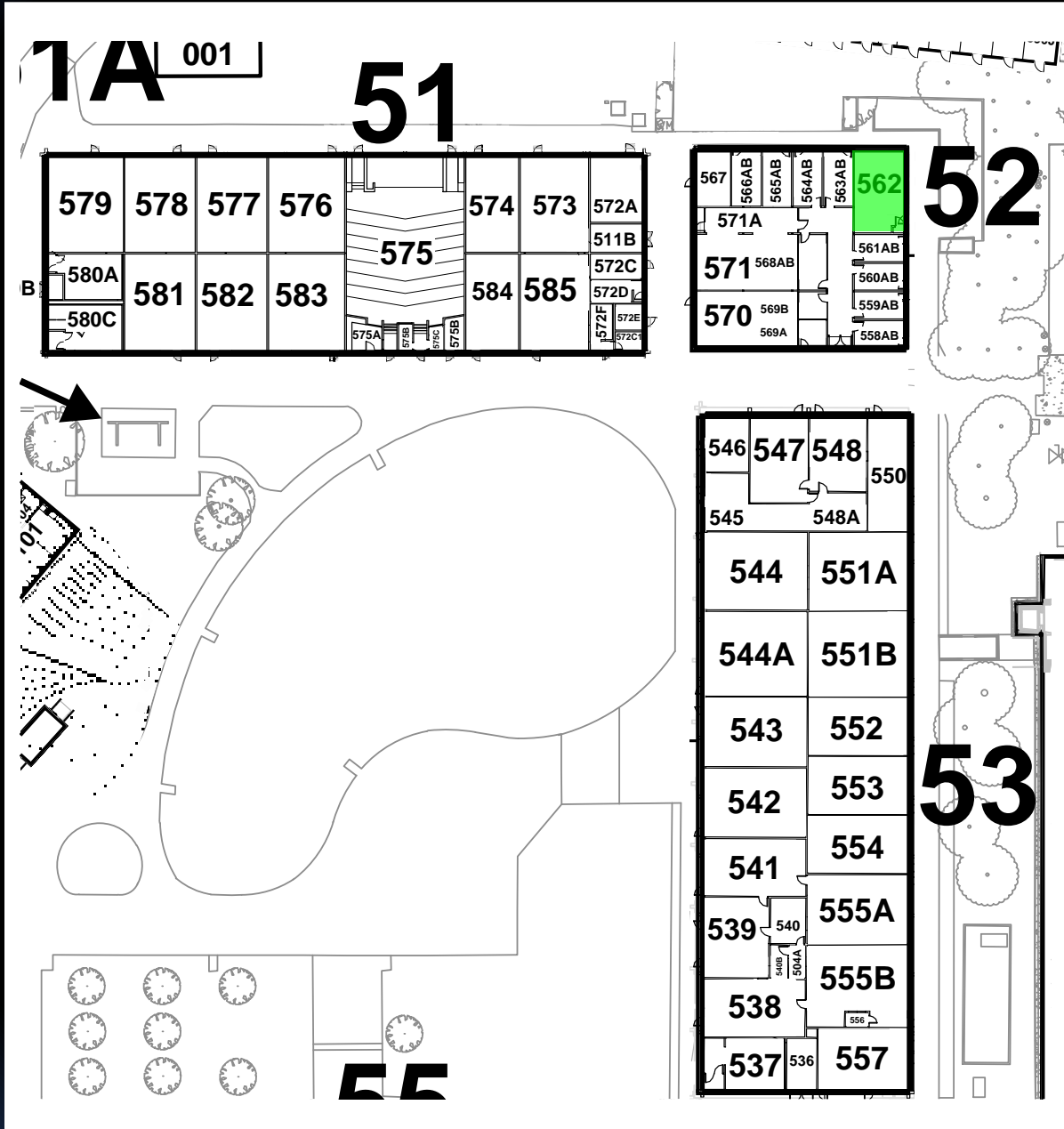

Currently under construction that will include new HVAC and paint



EXAMPLES



Meditation Room, University of Redlands

- ▣ Meditation
- ▣ Prayer
- ▣ Reflection
- ▣ Relaxation
- ▣ Yoga

WHO WILL BENEFIT?

- ▣ Students
- ▣ Staff
- ▣ Institution
- ▣ Community



Meditation Room, Santa Clara University

FPR 24-09 New Cabinets in Biology Bldg 30-128

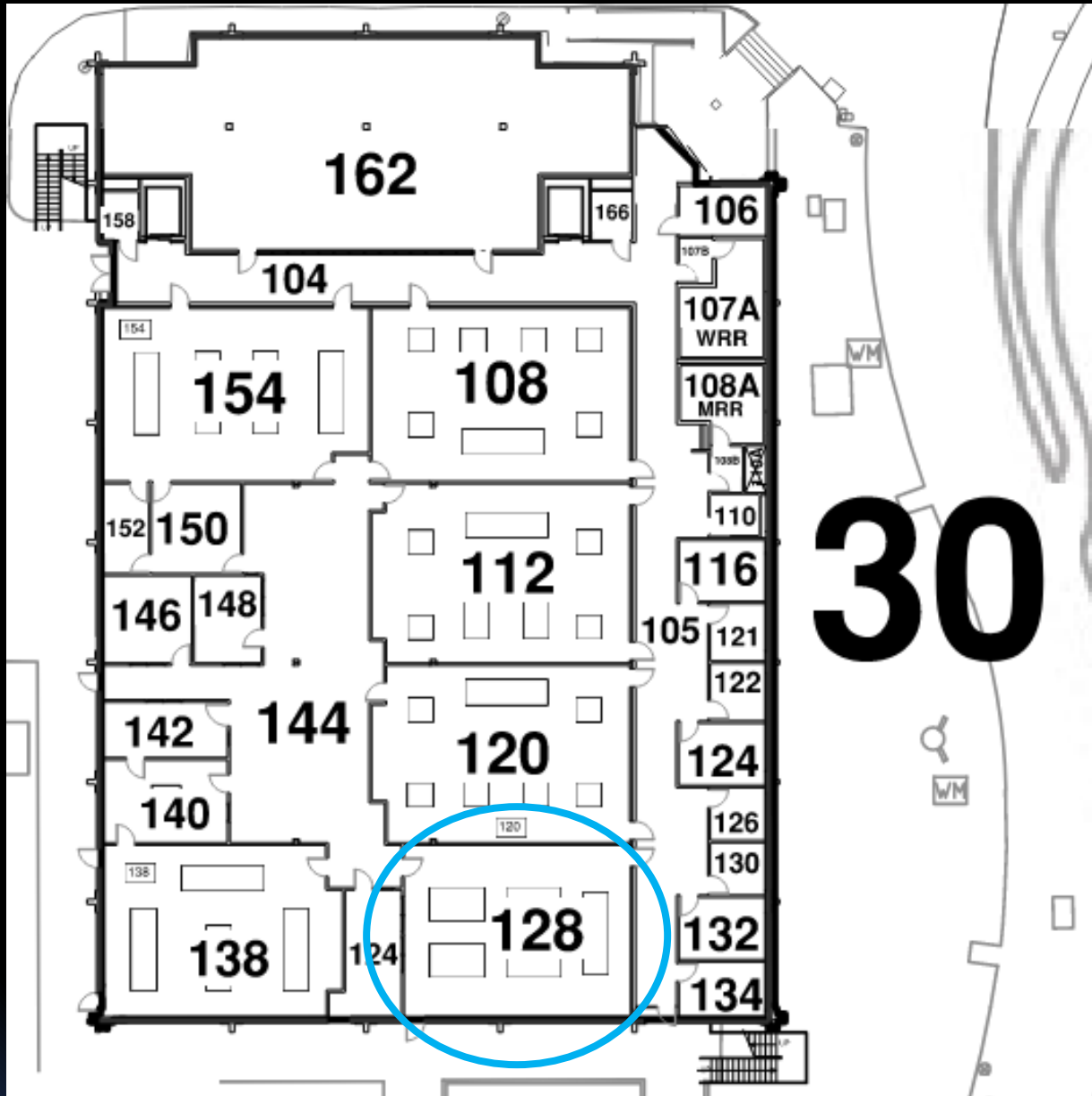

History for the needed cabinets

- Three chemical hoods were removed
- A temporary countertop was installed



New FPR

- Add upper cabinets similar to the other side of the lab



FPR 24-11 Biology Chairs

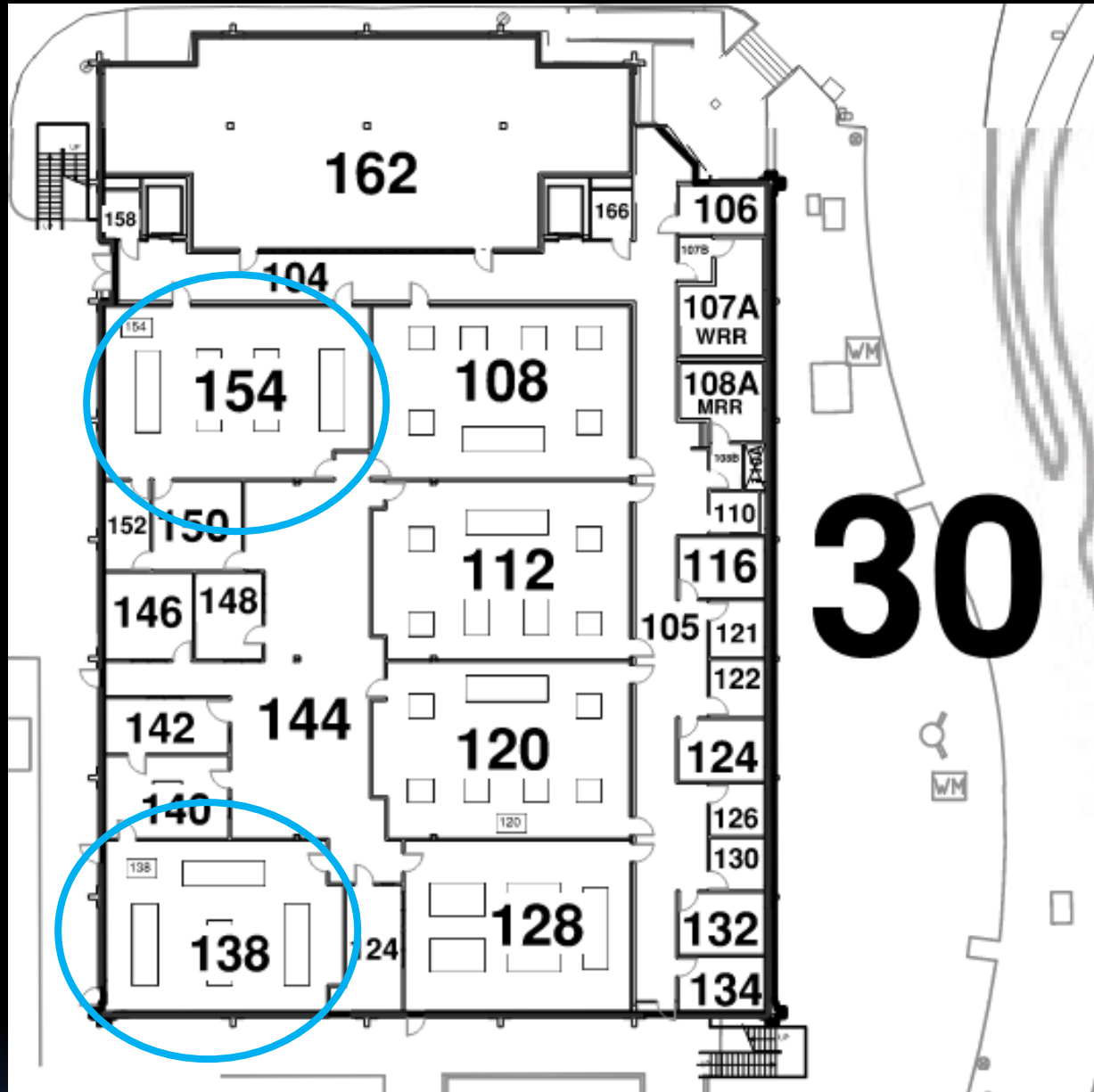

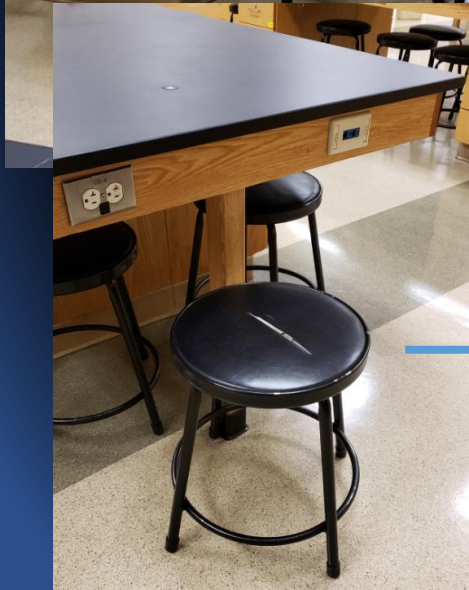

→ Change stools out with chairs with backs →



FPR Form 2

- 8) **FMO Impact:** Will your project require extensive labor or time from Facilities, Maintenance, & Operations staff?
 Yes
 No
 Unsure
- 9) **Benefit and Impact on Students:** How will this resource impact students' learning and/or experience (at the course/program/service level and/or engagement level)?
- 10) **Benefit and Impacts to the College Campus:** (How will this project enhance or impact other college programs, services, and/or operations?)
- 11) **Project support:** Does your project support one or more of the following? If so, please explain.
 College or District Facilities Master Plan _____
 Sustainability Impact _____
 ADA accessibility _____

Director's Report

TOTAL ESTIMATE COST	\$0	Including Public Works & Engineering
POSSIBLE COST REDUCTION	\$0	
TOTAL COST WITH REDUCTION	\$0	
Possible Criteria Scores: 0-5 with 5 the highest score		
(1) CONSTRUCTION IMPACT ON STUDENTS/STAFF	0	
(2) CONTINUAL IMPACT ON FMO	0	
(3) CONSTRUCTION IMPACT ON FMO	0	
(4) PROJECT PHYSICAL FEASIBILITY	0	
(5) PROJECT SUPPORT FEASIBILITY	0	
(6) COST FEASIBILITY	0	
(7) PROJECT START/FINISH FEASIBILITY	0	
NOTES		
Impact Score	0 through 4 (0= lowest, 4= highest)	
Feasibility Score	0 through 4 (0= lowest, 4= highest)	
Public Bid	0	
DSA	0	
Gafcon	0	
Proj. Manager	0	
In-House	0	
Contractor	0	
Join Projects	0	

FPR - Facilities Project Request Scorecard - Facilities Committee

Project Title:

FC Member:

Possible Criteria Scores: 0-5 with 5 the highest score

REFER TO QUESTION	CRITERIA	CRITERIA SCORE	
Benefits and Impacts			
A	3,4,9 Direct/indirect benefit for students	0	
B	3,4,9 Direct/indirect impact on students (0 = Impact, 5 = No Impact)	0	
C	3,4,10 Benefit for other depts., services, programs	0	
D	3,4,10 Impact on other depts., services, programs (0 = Impact, 5 = No Impact)	0	
E	5 Mission Priority	0	
F	5 Strategic Goals	0	
Project Support			
G	6 Legal Mandate	0	
H	6 Program/College Accreditation Criteria	0	
I	6 Health/Safety/OSHA Priorities	0	
J	6 Critical Threshold of Educational & Support Services	0	
K	6 Essential Operations	0	
L	6 College or District Facilities Master Plan	0	
M	6 Sustainability Impact	0	
N	6 ADA Accessibility	0	
Budget			
O	12 Potential/Recommended funding source	0	
P	12 One-Time Cost Effectiveness	0	
Q	12 Projected Long-Term Effectiveness	0	
R	12 Effective Life-Cycle (Replacement Time)	0	
S	12 Cost Feasibility	0	
Timeline			
T	7,13 Urgent Need	0	
U	7,13 Project Start/Finish Feasibility	0	
		Project Total Score Out of %100	0
Comments:			
Facilities Director Report			
Director's (1)	Construction impact on students/staff (0 = Impact, 5 = No Impact)	0	
Director's (2)	Continual impact on FMO (0 = Impact, 5 = No Impact)	0	
Director's (3)	Construction impact on FMO (0 = Impact, 5 = No Impact)	0	
Director's (4)	Project Physical Feasibility	0	
Director's (5)	Project Support Feasibility	0	
Director's (6)	Cost Feasibility	0	
Director's (7)	Project Start/Finish Feasibility	0	
		Project Total Score Out of %100	0
Comments:			

FACILITIES COMMITTEE AGENDA

1. Welcome/Introductions – Jennifer Bennett
2. Agenda – Additions/Deletions – Jennifer Bennett
3. Approve Meeting Minutes – Jennifer Bennett
4. 5-Minute Public Comment – Jennifer Bennett
5. Constituency Updates – Jennifer Bennett
 1. Admin Association
 2. Classified Senate
 3. Academic Senate
 4. ASGC
6. Space Utilization Update – Loren Holmquist
7. Sculpture Campus Art – Jennifer Bennett
8. AUP / FPR Prioritization – Loren Holmquist
9. **Construction Timeline and Impacts – Loren Holmquist**
10. Constituency Group Recap - Jennifer Bennett

DATE 3/6/24

Ribbon Cutting – Feb 15, 4 PM



GROSSMONT
COLLEGE

Math, Science & Career Tech Complex Phase 2-Building 36



GROSSMONT
AND
CUYAMACA
COMMUNITY COLLEGES



GROSSMONT-CUYAMACA
COMMUNITY COLLEGE DISTRICT

COMING IN **WINTER 2023**
View from lot 5 North



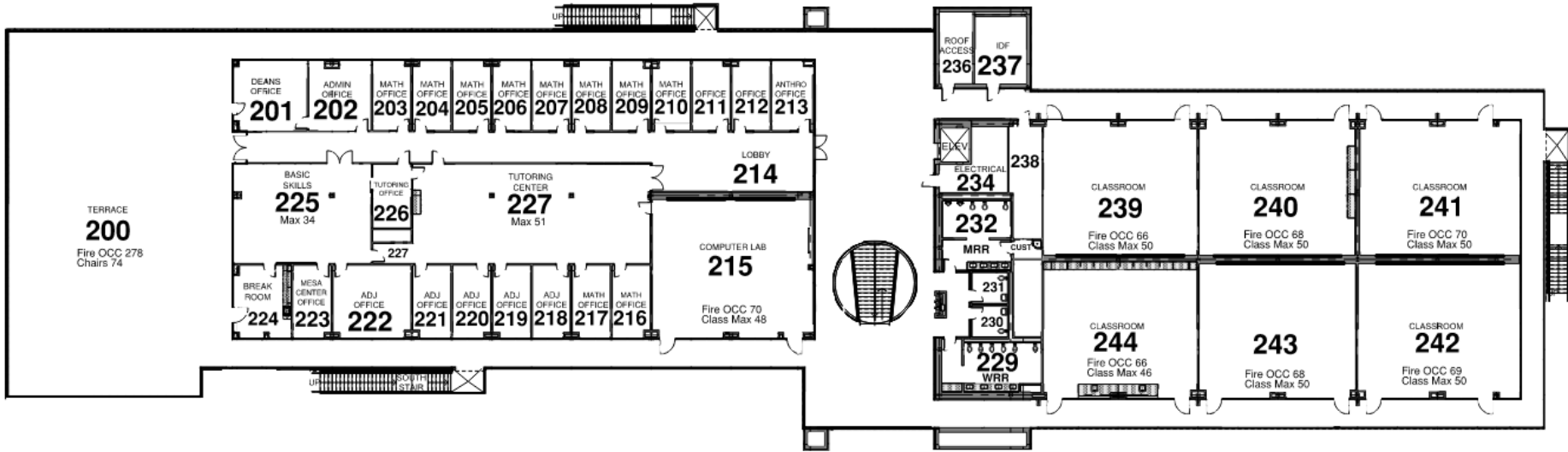

**BUILDING 36
SECOND FLOOR**

Bldg 36 Floorplan

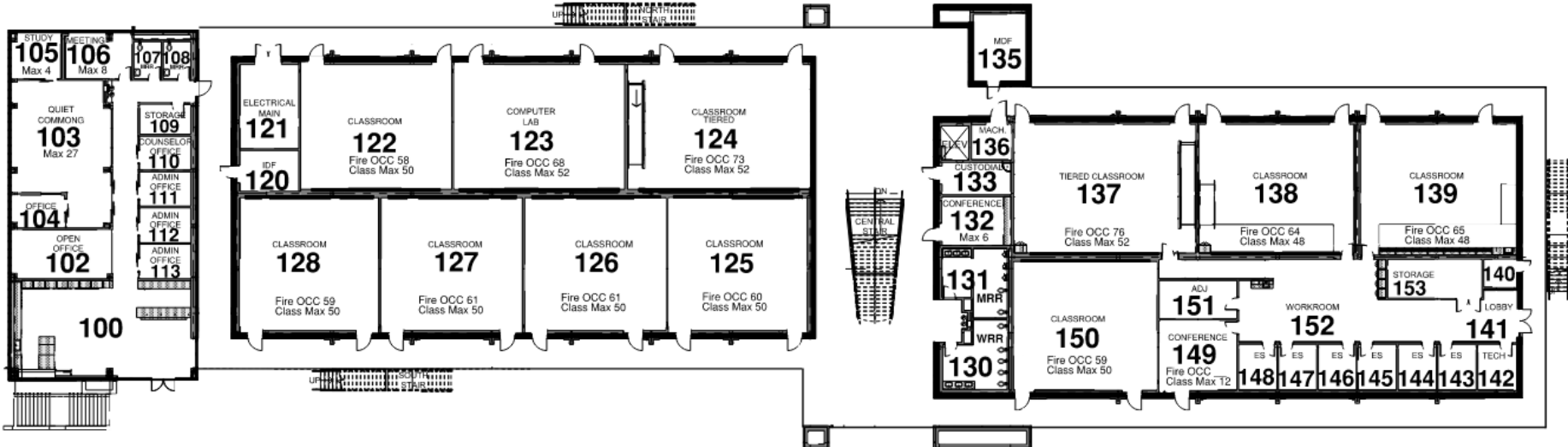

**BUILDING 36
FIRST FLOOR**

Bldg 52-54 Project

23.24 Projects

- Main Chiller extension to service Bldgs 51, 53 and 55
- Cosmetic upgrades to Bldgs 52-54
- Fan coil replacements in Bldgs 53 and 54
- Data and Power rerouting to Bldg 50
- Power rerouting to Bldg 54
- Installation of new electrical PME switches for Bldgs 51 and 55
- ADA concrete upgrades from the 500 complex to the bus stop area

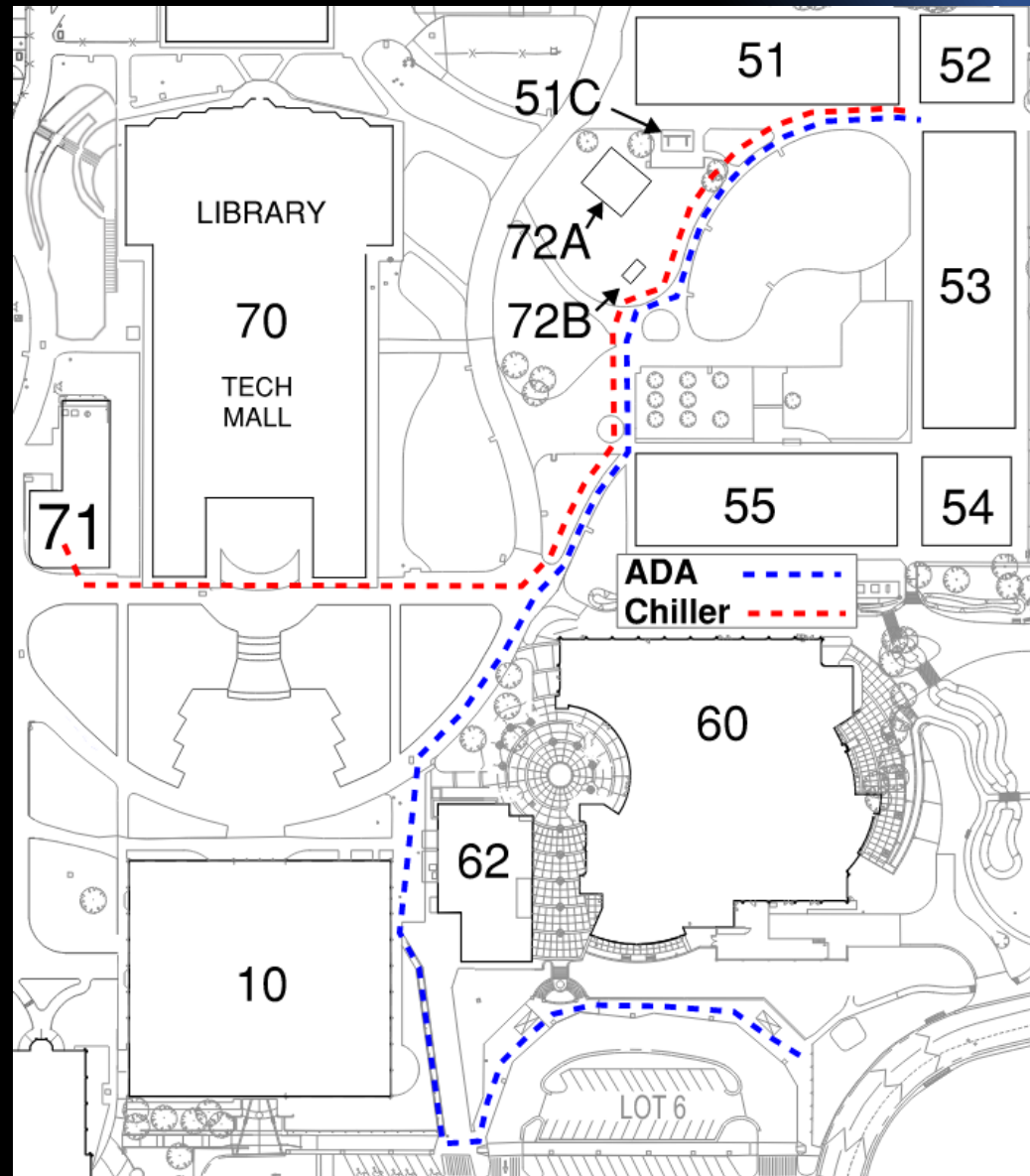

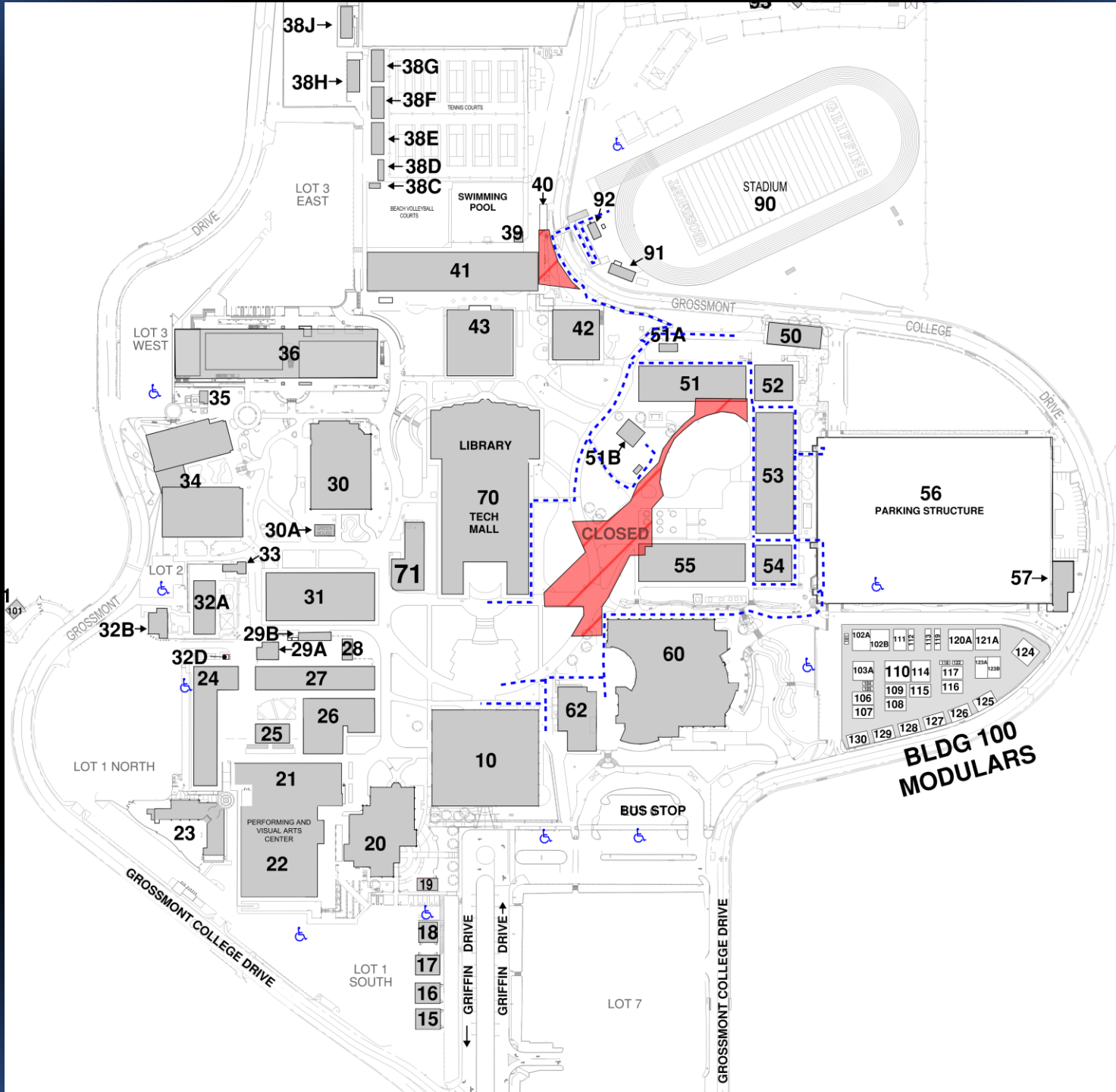

**BLDG 100
MODULARS**

Bldg 51/55 Renovation

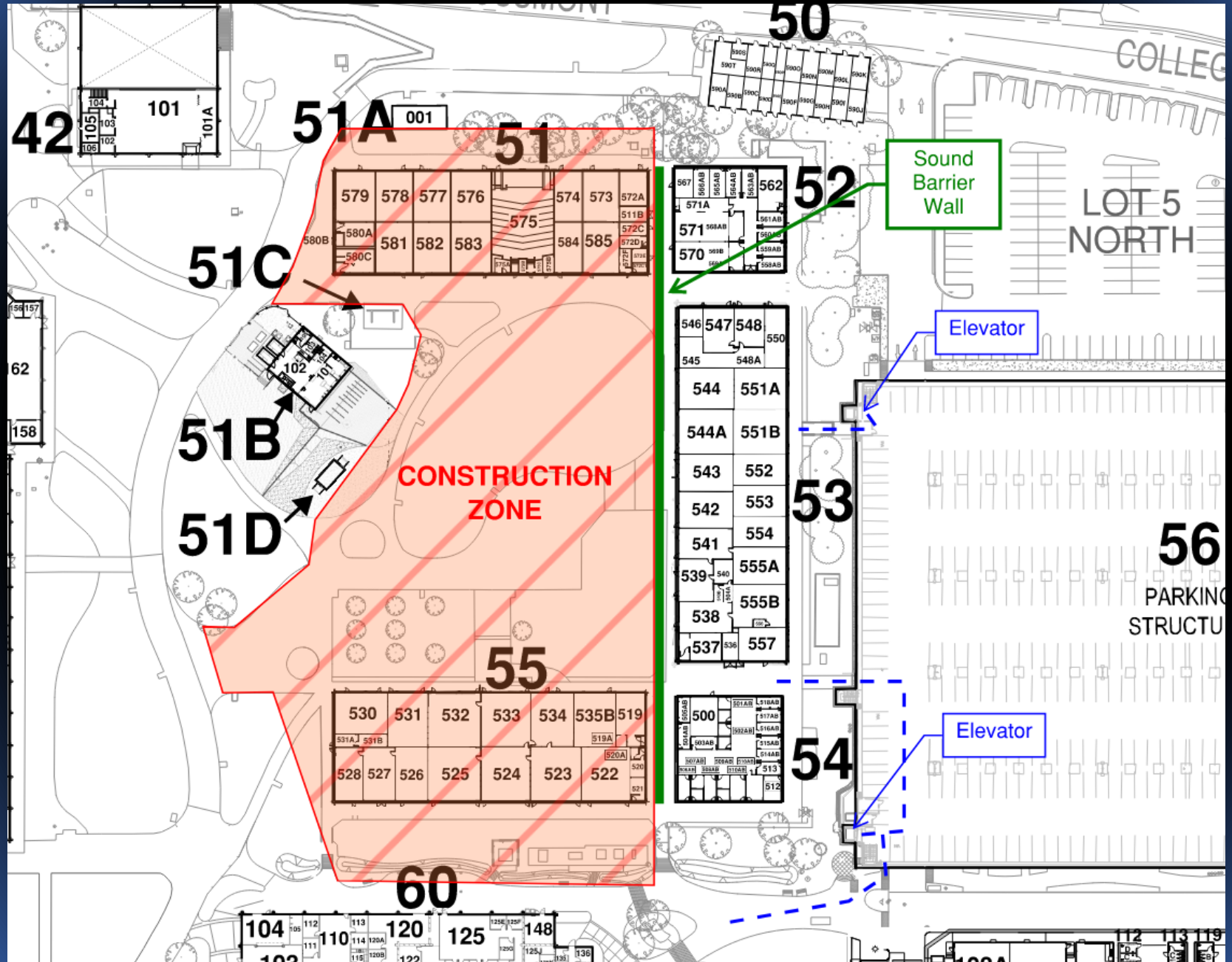

FACILITIES COMMITTEE AGENDA

1. Welcome/Introductions – Jennifer Bennett
2. Agenda – Additions/Deletions – Jennifer Bennett
3. Approve Meeting Minutes – Jennifer Bennett
4. 5-Minute Public Comment – Jennifer Bennett
5. Constituency Updates – Jennifer Bennett
 1. Admin Association
 2. Classified Senate
 3. Academic Senate
 4. ASGC
6. Space Utilization Update – Loren Holmquist
7. Sculpture Campus Art – Jennifer Bennett
8. AUP / FPR Prioritization – Loren Holmquist
9. Construction Timeline and Impacts – Loren Holmquist
10. **Constituency Group Recap - Jennifer Bennett**

DATE 3/6/24

WELCOME TO THE FACILITIES COMMITTEE

The best way to contact FMO is by email

Grossmont.FMO@gcccd.edu

For maintenance, grounds, custodial and operation needs

Colleen Parsons, Ryan Althaus, Bill Roessner, Pepe Levy, Joel Lopez

Grossmont.restrooms@gcccd.edu

For restrooms that need attention

FMO phone is not monitored 24/7

619-644-7594